

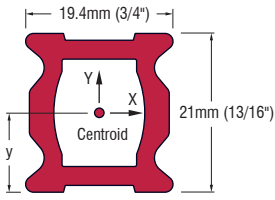

# TRAVELLER SYSTEM – TRACK DATA

- Beam tracks are typically used to span cockpits, companionways and unsupported deck sections, where fastening options are restricted or to avoid the need for building additional support structure into the boat.
- Sectional and mechanical data, including moments of inertia ( $I_{xx}$  &  $I_{yy}$ ) and cross sectional area (CSA) are shown below for the various beam sections. Designer or builder should be consulted to determine the appropriate section for a specific application.

**Typical Material Properties :**  $\sigma_{yield} = 90\text{mpa}$  (13.05ksi)  $\sigma_{ult} = 150\text{mpa}$  (21.76ksi)



**RC1194-2.0**

$I_{xx} = 9009\text{mm}^4$  (0.0216in<sup>4</sup>)  
 $I_{yy} = 7001\text{mm}^4$  (0.0168in<sup>4</sup>)  
 $y = 10.5\text{mm}$  (13/32")  
 $CSA = 179\text{mm}^2$  (0.277in<sup>2</sup>)

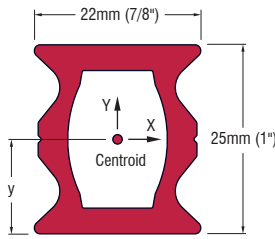

**RC1224-2.0**

$I_{xx} = 18212\text{mm}^4$  (0.0438in<sup>4</sup>)  
 $I_{yy} = 11441\text{mm}^4$  (0.0275in<sup>4</sup>)  
 $y = 12.5\text{mm}$  (1/2")  
 $CSA = 240\text{mm}^2$  (0.372in<sup>2</sup>)

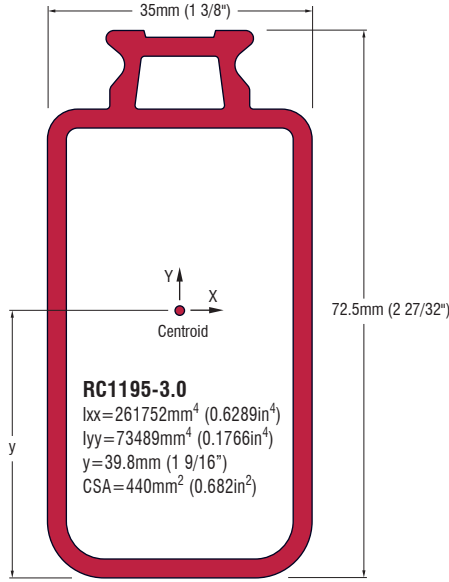

**RC1195-3.0**

$I_{xx} = 261752\text{mm}^4$  (0.6289in<sup>4</sup>)  
 $I_{yy} = 73489\text{mm}^4$  (0.1766in<sup>4</sup>)  
 $y = 39.8\text{mm}$  (1 9/16")  
 $CSA = 440\text{mm}^2$  (0.682in<sup>2</sup>)

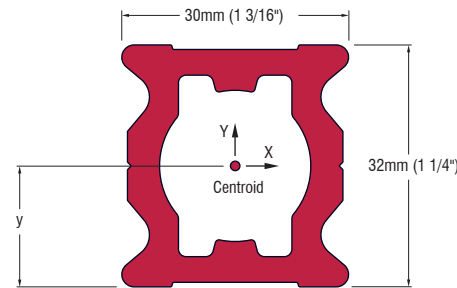

**RC1304-2.0**

$I_{xx} = 54234\text{mm}^4$  (0.1303in<sup>4</sup>)  
 $I_{yy} = 41776\text{mm}^4$  (0.1004in<sup>4</sup>)  
 $y = 16\text{mm}$  (5/8")  
 $CSA = 455\text{mm}^2$  (0.705in<sup>2</sup>)

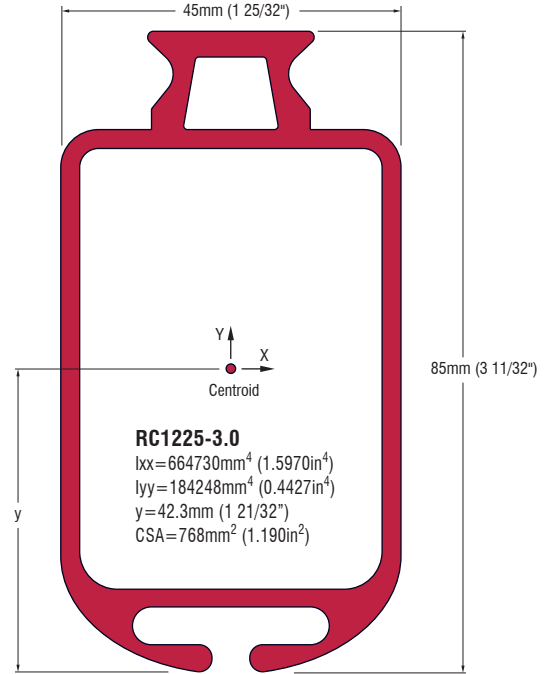

**RC1225-3.0**

$I_{xx} = 664730\text{mm}^4$  (1.5970in<sup>4</sup>)  
 $I_{yy} = 184248\text{mm}^4$  (0.4427in<sup>4</sup>)  
 $y = 42.3\text{mm}$  (1 21/32")  
 $CSA = 768\text{mm}^2$  (1.190in<sup>2</sup>)

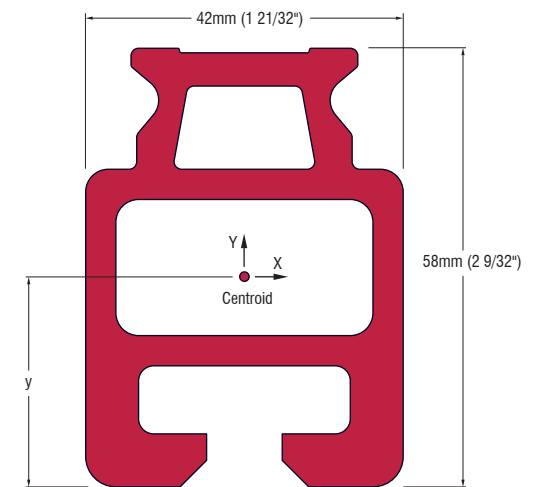

**RC1305B-3.0**

$I_{xx} = 338641\text{mm}^4$  (0.8136in<sup>4</sup>)  
 $I_{yy} = 202808\text{mm}^4$  (0.4872in<sup>4</sup>)  
 $y = 26.9\text{mm}$  (1 1/16")  
 $CSA = 1051\text{mm}^2$  (1.629in<sup>2</sup>)

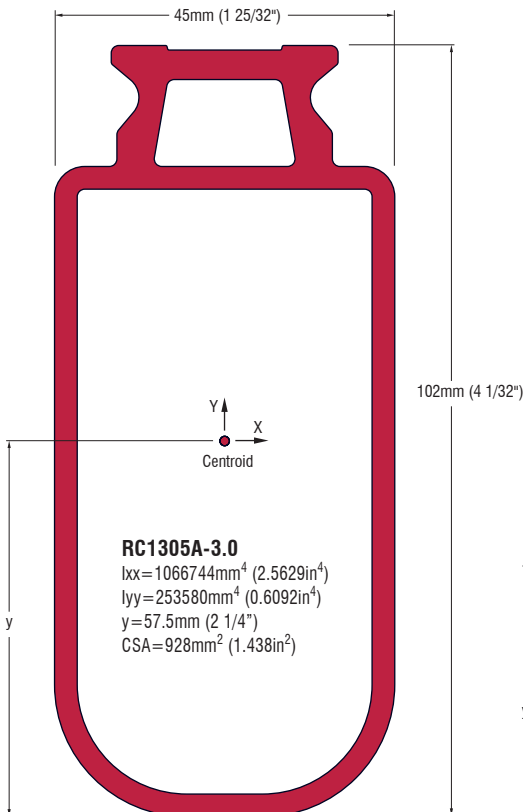

**RC1305A-3.0**

$I_{xx} = 1066744\text{mm}^4$  (2.5629in<sup>4</sup>)  
 $I_{yy} = 253580\text{mm}^4$  (0.6092in<sup>4</sup>)  
 $y = 57.5\text{mm}$  (2 1/4")  
 $CSA = 928\text{mm}^2$  (1.438in<sup>2</sup>)

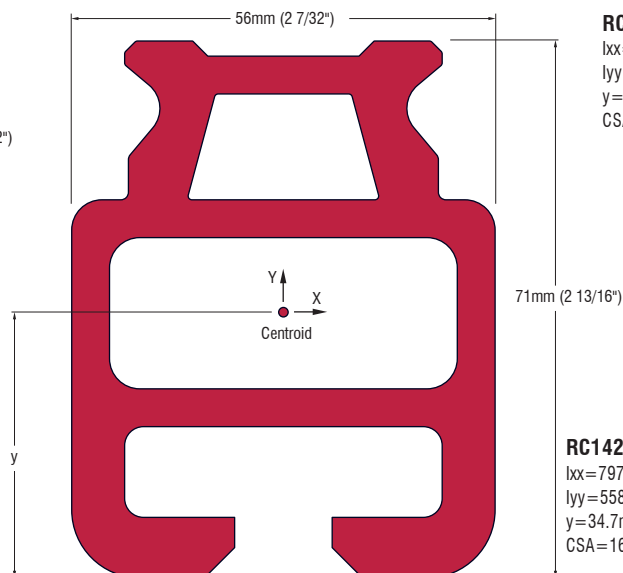

**RC1425-3.0**

$I_{xx} = 797749\text{mm}^4$  (1.9166in<sup>4</sup>)  
 $I_{yy} = 558530\text{mm}^4$  (1.3419in<sup>4</sup>)  
 $y = 34.7\text{mm}$  (1 3/8")  
 $CSA = 1687\text{mm}^2$  (2.614in<sup>2</sup>)

- In certain applications it is advantageous to curve tracks either horizontally ('A' bend) or vertically ('B' bend).
- Curved track may be needed to give a traveller car a required path of movement or to match the mounting surface to which it is fixed. It can also ensure maximum performance is obtained from a traveller car by ensuring load and connection remain vertical. Or that tension in an attached purchase system or linkage remains constant.

### Horizontal Plane – 'A' Bend

In situations where cars and fittings are required to rotate around a central pivot point, horizontal 'A' bending of the track will ensure the load applied to the car remains vertical. This results in maximum strength and free rolling ability being maintained by the car. Maintaining this vertical alignment also ensures tension in an attached purchase system remains constant, a feature often sought after in sailboat mainsheet and boom vang traveller systems.

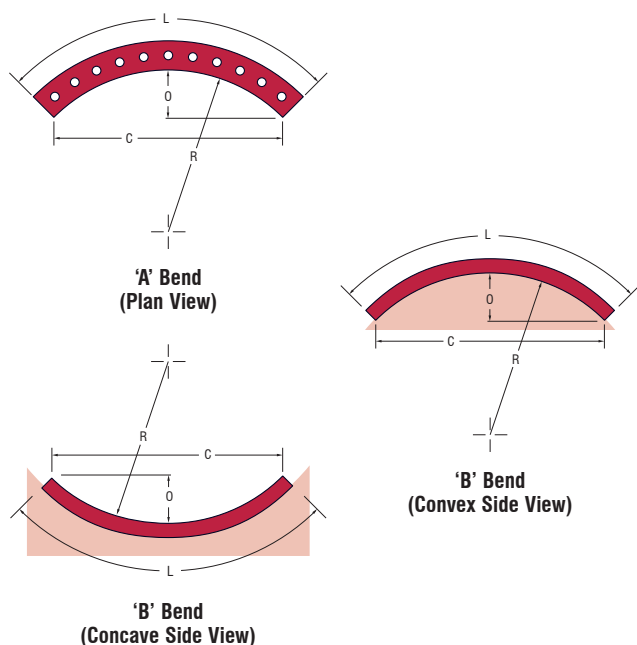

### Vertical Plane – 'B' Bend

Traveller tracks can be bent vertically to fulfil certain requirements. They can be top mounted or underhung mounted with either concave or convex track bends.

'B' Bends are often required to match the mounting surface to which a track is to be fixed; as when matching deck camber on a sailboat.

'B' bending can also be used to maintain constant tension in a rotating purchase system mounted on a traveller car. This application is very popular on sailboat mainsheet and self-tacking jib systems where the increased load applied to the car during tacking or gybing may affect sail trim or cause the car to stick.

### Minimum Bend Radius

| TRAVELLER SERIES | CAR LENGTH |           | MIN. HORIZONTAL "A" BEND RADIUS |             | MIN. VERTICAL "B" BEND RADIUS |             |             |
|------------------|------------|-----------|---------------------------------|-------------|-------------------------------|-------------|-------------|
|                  | mm         | (in.)     | mm                              | (in.)       | mm                            | (in.)       |             |
| SERIES 14        | 47         | (1 27/32) | 1300                            | (51 7/32)   | 800                           | (31 17/32)  |             |
|                  | 68         | (2 11/16) | 2000                            | (78 13/16)  | 2000                          | (78 13/16)  |             |
|                  | 78         | (3 1/16)  | 3500                            | (137 29/32) | 4500                          | (177 5/16)  |             |
| SERIES 19        | 50         | (1 31/32) | 1500                            | (59 3/32)   | 1500                          | (59 3/32)   |             |
|                  | 57         | (2 1/4)   | 1500                            | (59 3/32)   | 1500                          | (59 3/32)   |             |
|                  | 70         | (2 3/4)   | 2500                            | (98 1/2)    | 3000                          | (118 3/16)  |             |
|                  | 85         | (3 11/32) | 3500                            | (137 29/32) | 4500                          | (177 5/16)  |             |
|                  | 100        | (3 15/16) | 5000                            | (197)       | 5500                          | (216 11/16) |             |
|                  | 148        | (5 27/32) | 11000                           | (433 13/32) | 15000                         | (591)       |             |
| SERIES 22        | 60         | (2 3/8)   | 1500                            | (59 3/32)   | 1500                          | (59 3/32)   |             |
|                  | 75         | (2 31/32) | 1500                            | (59 3/32)   | 2000                          | (78 13/16)  |             |
|                  | 125        | (4 15/16) | 5000                            | (197)       | 5000                          | (197)       |             |
|                  | 130        | (5 1/8)   | 5000                            | (197)       | 5000                          | (197)       |             |
|                  | 165        | (6 1/2)   | 7000                            | (275 13/16) | 7500                          | (295 1/2)   |             |
|                  | 175        | (6 29/32) | 9000                            | (354 19/32) | 13000                         | (512 3/16)  |             |
|                  | 180        | (7 3/32)  | 9000                            | (354 19/32) | 13000                         | (512 3/16)  |             |
|                  | 205        | (8 1/16)  | 9000                            | (354 19/32) | 9000                          | (354 19/32) |             |
| SERIES 26        | 120        | (4 23/32) | 4000                            | (157 19/32) | 4000                          | (157 19/32) |             |
|                  | 180        | (7 3/32)  | 8000                            | (315 3/16)  | 8000                          | (315 3/16)  |             |
|                  | 200        | (7 7/8)   | 8000                            | (315 3/16)  | 8000                          | (315 3/16)  |             |
|                  | 205        | (8 1/16)  | 9000                            | (354 19/32) | 9000                          | (354 19/32) |             |
|                  | SERIES 30  | 77        | (3 1/16)                        | 2500        | (98 1/2)                      | 2500        | (98 1/2)    |
|                  |            | 100       | (3 15/16)                       | 2500        | (98 1/2)                      | 2500        | (98 1/2)    |
|                  |            | 150       | (5 29/32)                       | 8000        | (315 3/16)                    | 8000        | (315 3/16)  |
|                  |            | 165       | (6 1/2)                         | 8500        | (334 29/32)                   | 8500        | (334 29/32) |
|                  |            | 175       | (6 29/32)                       | 9000        | (354 19/32)                   | 9000        | (354 19/32) |
|                  |            | 185       | (7 9/32)                        | 9300        | (366 13/32)                   | 9300        | (366 13/32) |
| 200              |            | (7 7/8)   | 10000                           | (394)       | 10000                         | (394)       |             |
| 215              |            | (8 15/32) | 11000                           | (433 13/32) | 11000                         | (433 13/32) |             |
| 225              |            | (8 7/8)   | 16000                           | (630 13/32) | 16000                         | (630 13/32) |             |
| 230              |            | (9 1/16)  | 16500                           | (650 3/32)  | 16500                         | (650 3/32)  |             |
| 300              | (11 13/16) | 15000     | (591)                           | 15000       | (591)                         |             |             |
| 375              | (14 25/32) | 18000     | (709 3/16)                      | 18000       | (709 3/16)                    |             |             |

Please contact our sales team for minimum bend radius requirements for Series 42 and 55 traveller cars.

### CURVED TRACK SPECIFICATION REQUIREMENTS

Specifications are required for each type of bend, including two critical dimensions (three if possible), and clear drawings where possible.

#### Critical Dimension Required

|        |          |     |                 |          |
|--------|----------|-----|-----------------|----------|
| Radius | <b>R</b> | and | Offset          | <b>O</b> |
|        |          | OR  |                 |          |
| Radius | <b>R</b> | and | Length of Track | <b>L</b> |
|        |          | OR  |                 |          |
| Radius | <b>R</b> | and | Chord Length    | <b>C</b> |
|        |          | OR  |                 |          |
| Offset | <b>O</b> | and | Chord Length    | <b>C</b> |

In many 'B' bend situations, the radius R is not known and it is easiest to specify the curve by C (chord length) and O (offset) values. In these cases, the radius the track is to follow MUST be constant.

### It should be noted that:

- ▶ Although track bends may appear desirable to provide ideal alignment and avoid angular loads being applied to the car, in a ball bearing system this same bend will actually reduce the load capacity of the system by loading the balls unevenly throughout the length of the car.
  - ▶ Not all track types are suited to both types of bends, and some tracks cannot be curved at all.
  - ▶ A minimum track radius is specified for each length of traveller car. This is the tightest curve a car will run around freely. Refer to the recommendation table above for each track type regarding suitability and minimum radius values.
  - ▶ Light bends can be 'sprung in' sometimes when mounting track, however considerable care must be taken to ensure that the curves are even with no tight spots and that the track is not overbent (permanently deformed) during installation.
- For the best results, track should be ordered pre-bent from Ronstan.

### Ordering

1. Specify the type of track profile (by product no.)
2. The type of bend required 'A' Bend (horizontal) or 'B' Bend (vertical) Concave or Convex.
3. Provide the appropriate dimensional specifications as described above.